

HEAVY DUTY PROJECTOR CEILING MOUNTS

nT7CB07



☐ WHITE



☐ BLACK



DESCRIPTION

The nT7CB07 is a heavy projector ceiling mount best suited for heavy and large projectors. Easy installation with simple 360 degree rotation pan and tilt adjustment, adjustable height, large mounting pitch. Cable management through the telescopic pole. Weight capacity up to 30 kgs. Available in elegant Matt Black and Matt white color with options of various drop down heights. Available sizes 1.5-2ft, 2-3ft, 6-10ft – customized lengths. Suitable for auditoriums, Cinema, Amphitheatre, 3D Mapping, Digital signage.



Specification

Material	: MS steel
Height adjustment	: Sliding in inner and outer tube
Pan and tilt	: +25 & -25 Degree
Rotation	: 360 Degree
Max mounting pitch	: 500 mm
Weight capacity	: Up to 30 kgs
Height variants	: 1.5-2 ft, 2-3 ft, 2.5-4 ft, 3-6 ft, 10ft
Color	: Black/White
Optional	: Back Cover

Premium
BLACK & WHITE
COLOUR

Premium Build
With Matt finish

360° Rotational
Adjustments

Height Adjustments

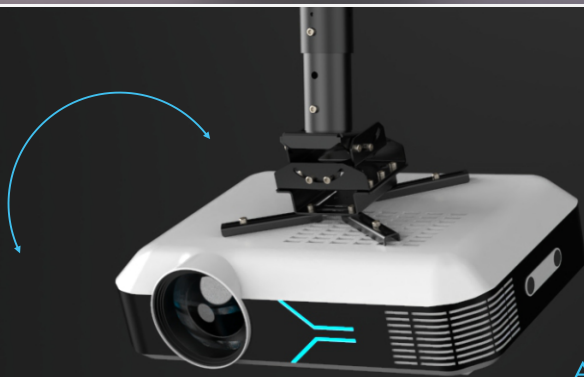
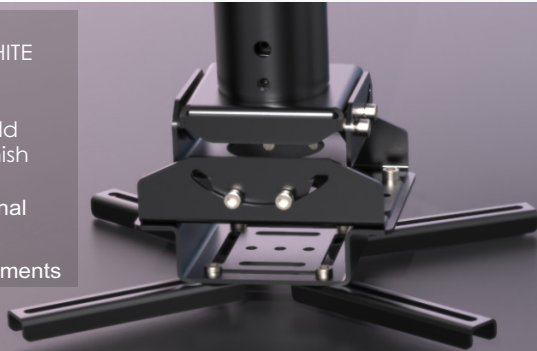

Angle Adjustments
Upto 55°

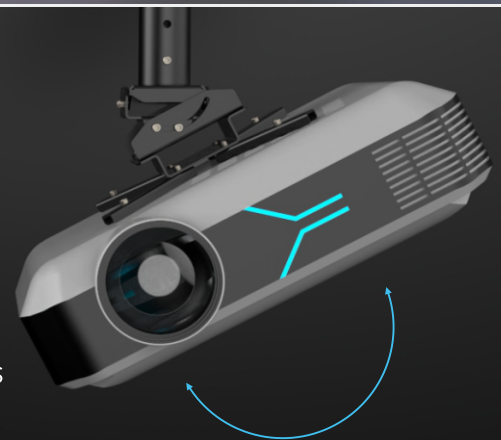

Webpage



Youtube



HEAVY DUTY PROJECTOR CEILING MOUNTS

nT7CB07

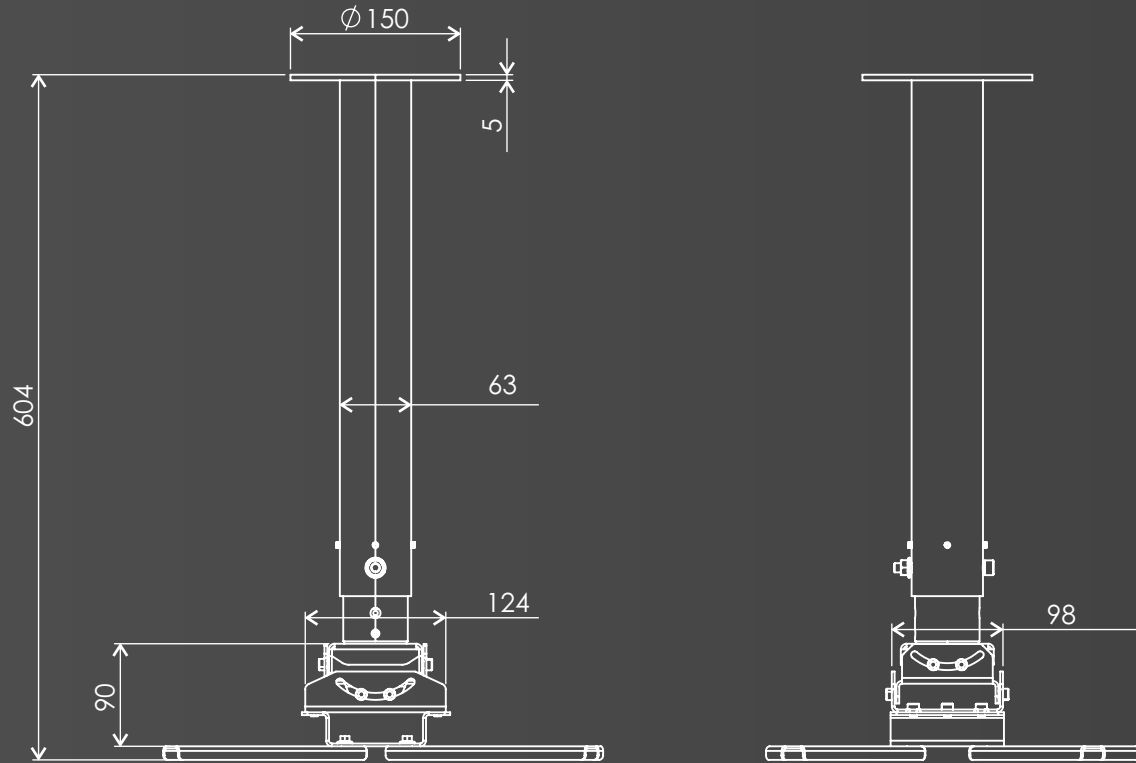

All dimensions are in mm



FINGER SIZES

