

SOLUTIONS FOR GROWTH



nT14AX16 | CPLUS-V32USBC

UHD* 3X2 Matrix Switcher with USB Ethernet Hub



Operation Manual

HDMI[®]
HIGH-DEFINITION MULTIMEDIA INTERFACE

The terms HDMI, HDMI High-Definition Multimedia Interface, and the HDMI Logo are trademarks or registered trademarks of HDMI licensing Administrator, Inc.

DISCLAIMERS

The information in this manual has been carefully checked and is believed to be accurate. Cypress Technology assumes no responsibility for any infringements of patents or other rights of third parties which may result from its use.

Cypress Technology assumes no responsibility for any inaccuracies that may be contained in this document. Cypress also makes no commitment to update or to keep current the information contained in this document.

Cypress Technology reserves the right to make improvements to this document and/or product at any time and without notice.

COPYRIGHT NOTICE

No part of this document may be reproduced, transmitted, transcribed, stored in a retrieval system, or any of its part translated into any language or computer file, in any form or by any means—electronic, mechanical, magnetic, optical, chemical, manual, or otherwise—without express written permission and consent from Cypress Technology.

© Copyright 2018 by Cypress Technology.

All Rights Reserved.

TRADEMARK ACKNOWLEDGMENTS

All products or service names mentioned in this document are trademarks of the companies with which they are associated.



SAFETY PRECAUTIONS

Please read all instructions before attempting to unpack, install or operate this equipment and before connecting the power supply. Please keep the following in mind as you unpack and install this equipment:

- Always follow basic safety precautions to reduce the risk of fire, electrical shock and injury to persons.
- To prevent fire or shock hazard, do not expose the unit to rain, moisture or install this product near water.
- Never spill liquid of any kind on or into this product.
- Never push an object of any kind into this product through any openings or empty slots in the unit, as you may damage parts inside the unit.
- Do not attach the power supply cabling to building surfaces.
- Use only the supplied power supply unit (PSU). Do not use the PSU if it is damaged.
- Do not allow anything to rest on the power cabling or allow any weight to be placed upon it or any person walk on it.
- To protect the unit from overheating, do not block any vents or openings in the unit housing that provide ventilation and allow for sufficient space for air to circulate around the unit.
- Please completely disconnect the power when the unit is not in use to avoid wasting electricity.

VERSION HISTORY

REV.	DATE	SUMMARY OF CHANGE
RDV1	2020/10/29	Preliminary release



CONTENTS

1. Introduction	1
2. Applications	1
3. Package Contents	1
4. System Requirements	2
5. Features	2
6. Operation Controls And Functions	3
6.1 Front Panel.....	3
6.2 Rear Panel.....	4
6.3 RS-232 Pinouts and Defaults	5
6.4 WebGUI Control	6
6.4.1 AV Switch Tab.....	8
6.4.2 USB Settings Tab	10
6.4.3 Automation Tab.....	11
6.4.4 EDID Tab.....	14
6.4.5 Network Tab	16
6.4.6 System Tab.....	17
6.5 Telnet Control	18
6.6 Serial and Telnet Commands	18
7. Connection Diagram	43
8. Specifications	44
8.1 Technical Specifications	44
8.2 Video Specifications	45
8.3 Audio Specifications	47
8.3.1 Digital Audio	47
8.3.2 Analog Audio	47
8.4 Cable Specifications.....	48
9. Acronyms	49



1. INTRODUCTION

This 3×2 matrix switch is designed for use in environments needing a wide range of flexibility when it comes to inputs, outputs, and control. The two most common video input interfaces (HDMI, USB-C) are included along with a pair of HDMI outputs and a single analog audio breakout port, providing the ultimate in source compatibility and flexibility.

All inputs and outputs on this unit are HDCP 2.2 compliant and provide support for resolutions up to a maximum of 4K@60Hz (4:4:4, 8-bit or 4:2:0, 12-bit HDR). The included USB-C input complies with the USB 3.0 standard and supports audio/video bypass, and device charging, as well as the ability to provide a network connection.

This matrix also includes standard USB 3.0 hub functionality with two host ports (one Type-B and one Type-C), plus two device ports (Type-A) for a flexible KVM configuration. It is ideal for use in meeting rooms or classrooms. This unit is controllable via front panel controls, WebGUI, Telnet and RS-232.

2. APPLICATIONS

- Home entertainment room
- Lecture hall display and control
- Showroom displays
- Meeting room presentation and control
- Classroom presentations

3. PACKAGE CONTENTS

- 1× UHD* 3×2 Matrix Switcher with USB Ethernet Hub
- 1× 24V/5A DC Power Adapter
- 1× Shockproof Feet (Set of 4)
- 1× Operation Manual

4. SYSTEM REQUIREMENTS

- HDMI or USB-C source equipment such as media players, video game consoles, laptops, or set-top boxes.
- HDMI receiving equipment such as HDTVs, monitors, or audio amplifiers.
- The use of Premium High Speed HDMI cables is highly recommended.

5. FEATURES

- HDMI 2.0 and DVI 1.0 compliant
- HDCP 1.x and 2.2 compliant
- 1 USB Type-C and 2 HDMI inputs
- 2 HDMI outputs with independent matrix switching and auto-switch support
- Supports up to 4K UHD (18Gbps, 4K@60Hz 4:4:4, 8-bit) video input and output
- Supports Deep Color input and output up to 12-bit
- Supports 10-bit and 12-bit HDR (High Dynamic Range) input/output
- Supports pass-through of many audio formats including 8 channel LPCM, Bitstream, and HD Bitstream
- HDMI Output A supports 4K to 1080p downscaling
- USB-C port functionality is switchable between a A/V focused mode (4K@60Hz) with USB 2.0 data and a mixed media mode with simultaneous A/V (4K@30Hz), USB 3.0, and Ethernet support
- USB-C port provides up to 20V/3A (60W) power to the connected device
- Supports pass-through of 8 channel LPCM, bitstream & HD bitstream audio formats
- Analog audio output source audio can be from output A or B (LPCM 2.0 sources only)
- Integrated USB 3.0 hub with one dedicated Type-B host port and two Type-A device ports (The USB-C port may optionally be used as an alternate host port)
- Supports basic signal event automation (via RS-232, Ethernet, or CEC)
- Controllable via front panel controls, WebGUI, Telnet and RS-232

6. OPERATION CONTROLS AND FUNCTIONS

6.1 Front Panel

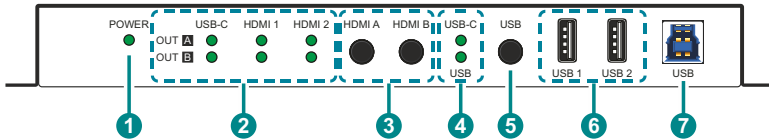

- 1 POWER LED:** This LED will illuminate to indicate the unit is on and receiving power.
- 2 OUT A & B LEDs:** The illuminated LED indicates which source is currently selected for each output.
- 3 HDMI A & HDMI B Buttons:** Press either button to sequentially switch through the available inputs for the associated HDMI output.
- 4 USB-C & USB LEDs:** The illuminated LED indicates which USB host port is currently active.
- 5 USB Button:** Press this button to select which USB host port is currently active. “USB” selects the USB Type-B port on the front of the unit, “USB-C” selects the USB Type-C port on the rear of the unit.
- 6 USB 1 & 2 Device Ports (Type-A):** Connect directly to standard USB devices such as a mouse, keyboard or flash drive to extend their USB functionality to the currently active USB host port.
- 7 USB Host Port (Type-B):** Connect directly to a standard USB host such as a PC or laptop to extend their USB functionality to all currently connected USB devices.

Note: Only active when the USB mode selection is set to “USB”.

6.2 Rear Panel

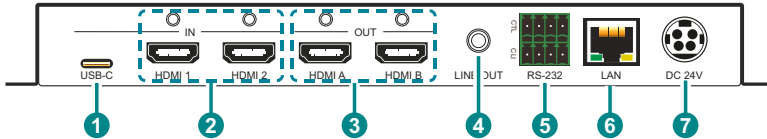

- 1 USB-C IN Port:** Connect to USB Type-C host or video source equipment such as a PC or laptop. When the USB-C port has “Super Speed” support active, this port can support 4K30 A/V, Ethernet, and USB simultaneously. When “Super Speed” is disabled, this port will support full bandwidth 4K60 A/V content but USB data functionality will be limited to USB 2.0 levels.

Note: Not all devices with USB Type-C ports can support video output. Please verify that the device supports video output from the USB Type-C port before attempting to use it as a video source.

- 2 HDMI IN 1 & 2 Ports:** Connect to HDMI source equipment such as media players, game consoles, or set-top boxes. DVI sources are supported with the use of an HDMI to DVI adapter.
- 3 HDMI OUT A & B Ports:** Connect to HDMI TVs, monitors, or amplifiers for digital video and audio output.
- 4 LINE OUT Port:** Connect to powered speakers, headphones, or an amplifier for analog stereo audio output extracted from the selected HDMI output (LPCM 2.0 sources only).
- 5 RS-232 CTL 4-pin Terminal Block:** Connect to the device you wish to control via a 3-pin adapter cable to receive event automation RS-232 commands from the unit.

RS-232 CLI 4-pin Terminal Block: Connect directly to a PC, laptop, or other serial control device with a 3-pin adapter cable to send RS-232 commands to control the unit.

Note: The 24 volt pins are included to provide power to a dedicated external control product and should NOT be used when connecting a standard RS-232 device.

- 6 LAN Port:** Connect directly, or through a network switch, to your PC/laptop to control the unit via Telnet/WebGUI and to extend the network across the USB Type-B and Type-C ports.

Note: The USB Type-C port must be in “Super Speed” mode to support Ethernet extension.

- 7 DC 24V Port:** Plug the 24V DC power adapter into this port and connect it to an AC wall outlet for power.

6.3 RS-232 Pinouts and Defaults

Serial Port Default Settings	
Baud Rate	19200
Data Bits	8
Parity Bits	None
Stop Bits	1
Flow Control	None

RS-232 Port 1 (CTL)

4-pin Terminal Block

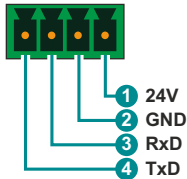

RS-232 Port 2 (CLI)

4-pin Terminal Block

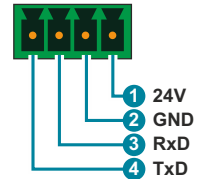

Note: The 24 volt pins (pin 1) are included to provide power to a dedicated external control product and should NOT be used when connecting a standard RS-232 device

6.4 WebGUI Control

• Device Discovery

Please obtain the “Device Discovery” software from your authorized dealer and save it in a directory where you can easily find it.

Connect the unit and your PC/Laptop to the same active network and execute the “Device Discovery” software. Click on “Find Devices on Internet” and a list of devices connected to the local network will show up indicating their current IP address.

Note: The unit’s default IP address is 192.168.1.50.

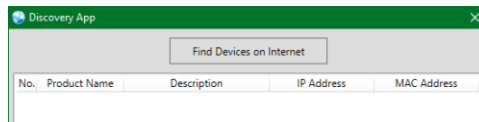

By clicking on one of the listed devices you will be presented with the network details of that particular device.

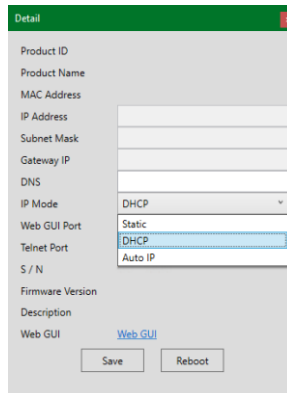

- 1) **IP Mode:** If you choose, you can alter the static IP network settings for the device, or switch the unit into DHCP mode to automatically obtain proper network settings from a local DHCP server. To switch to DHCP mode, please select DHCP from the IP mode drop-down, then click “Save” followed by “Reboot”.
- 2) **WebGUI Hotkey:** Once you are satisfied with the network settings, you may use them to connect via Telnet or WebGUI. The network information window provides a convenient link to launch the WebGUI directly.

- **WebGUI Overview**

After connecting to the WebGUI's address in a web browser, the login screen will appear. Please enter the appropriate user name and password then click "Submit" to log in.

Note: The default user name and password is "admin".

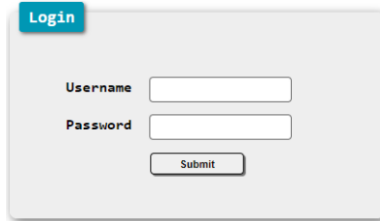

A login form with a blue "Login" button at the top left. Below it are two input fields: "Username" and "Password". At the bottom is a "Submit" button.

On the left side of the browser you will see the following menu tabs where all primary functions of the unit are controllable via the built in WebGUI. The individual functions will be introduced in the following sections.

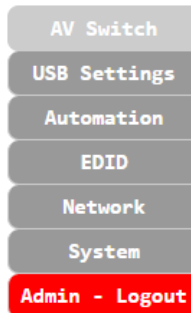

Clicking the red "Logout" tab will automatically log the currently connected user out of the WebGUI and return to login page.

6.4.1 AV Switch Tab

This tab provides A/V routing control, HDCP management, auto switch control, analog audio controls, and I/O renaming options. To assign a new A/V route, select one or both output buttons on the left and then click on the button of the preferred input source on the right. As each button is selected they will become highlighted. The new route will become active immediately and the routing information displayed on the buttons will change accordingly.

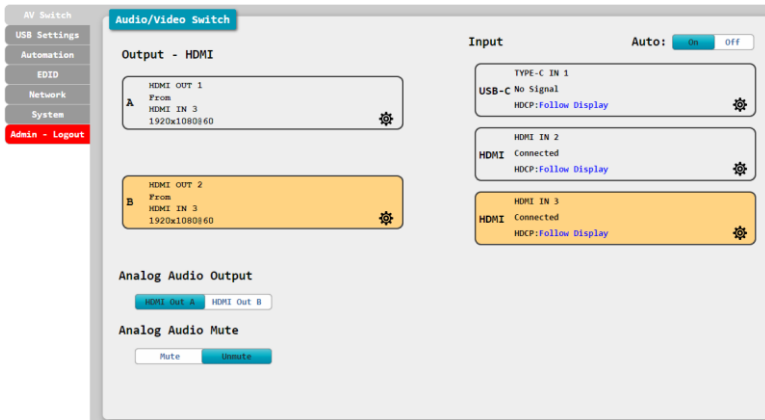

- 1) **Output:** These buttons display each output's name and details about the currently routed inputs. Clicking on the "Edit" icon (⚙️) opens up the Output Edit window.
- 2) **Input:** Buttons for selecting the input to route to an output. Details about each input's name and current sync/HDCP settings are also displayed here. Clicking on the "Edit" icon (⚙️) opens up the Input Edit window.
- 3) **Auto:** Auto input switching may be enabled or disabled by clicking on the On/Off slider to toggle the setting.

Note: This setting affects the source selection behavior for both outputs at the same time.

- 4) **Output Edit:** Provides control over the name of the output and, for output A only, control over the 4K2K downscale options.

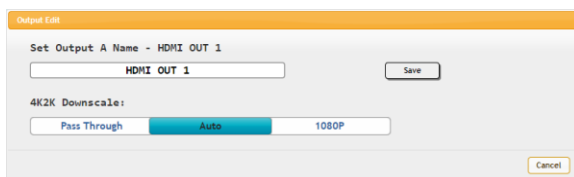

Set Output Name: To rename the output, type the new name in the space provided in the edit window. The name can be up to 32 characters long. Click the “Save” button to confirm the change.

4K2K Downscale: Select the 4K to 1080p downscaling behavior for output A.

- **Pass Through:** Send all signals through without any modification.
- **Auto:** Only activate the downscaling function if the EDID of the connected display does not support 4K.
- **1080P:** Downscalls all 4K sources to 1080p.

Note: This option is available for output A only. When active, no framerate conversion is performed. For example, a 4K@24Hz source would be output as 1080p@24Hz.

- 5) **Input Edit:** Provides individual control over the name of each input as well as the behavior of HDCP on that input.



Set Input Name: To rename an input, type the new name in the space provided in the edit window. The name can be up to 32 characters long. Click the “Save” button to confirm the change.

HDCP: Selects the HDCP logic to use with this HDMI input. Changes made to this setting occur immediately.

- **Disabled:** Completely disables support for HDCP on this input.
- **Follow Source:** Makes the input port support the same HDCP version as required by the connected source.
- **Follow Display:** Makes the input support the HDCP version of the currently routed display(s).

- 6) **Analog Audio Output:** Select the audio source for the analog audio output.

Note: Only LPCM 2.0 sources are supported.

- 7) **Analog Audio Mute:** Mute or unmute the analog audio output.

6.4.2 USB Settings Tab

This tab provides control over the settings for the USB ports on the unit.

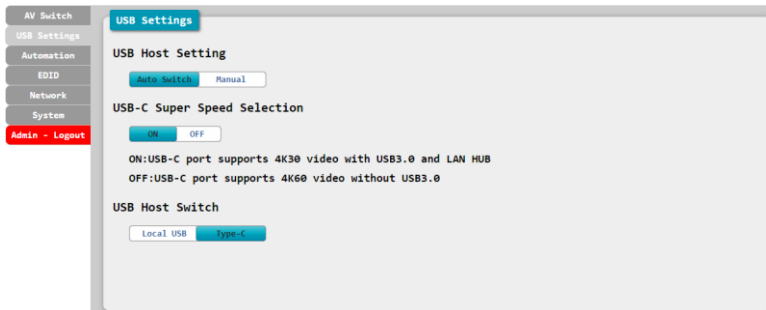

- 1) **USB Host setting:** Enable or disable automatic selection of the USB host port.
- 2) **USB-C Super Speed Selection:** Select the operational mode of the USB Type-C port. When “Super Speed” is turned on, the Type-C port can support 4K30 A/V, Ethernet, and USB simultaneously. When “Super Speed” is turned off, the Type-C port will support full bandwidth 4K60 A/V content but USB data functionality will be limited to USB 2.0 levels.
- 3) **USB Host Switch:** Select which USB host port is active on the internal USB hub. Selecting “Local USB” will make the Type-B port on the front of the unit active. Selecting “Type-C” will make the Type-C port on the rear of the unit active.

6.4.3 Automation Tab

This tab provides control over the unit's automatic control command broadcast behavior when any of the specified Automation Events occur. Automation commands can control connected devices via CEC, RS-232, and Telnet.

Note: CEC events are only sent to the device connected to HDMI output A.

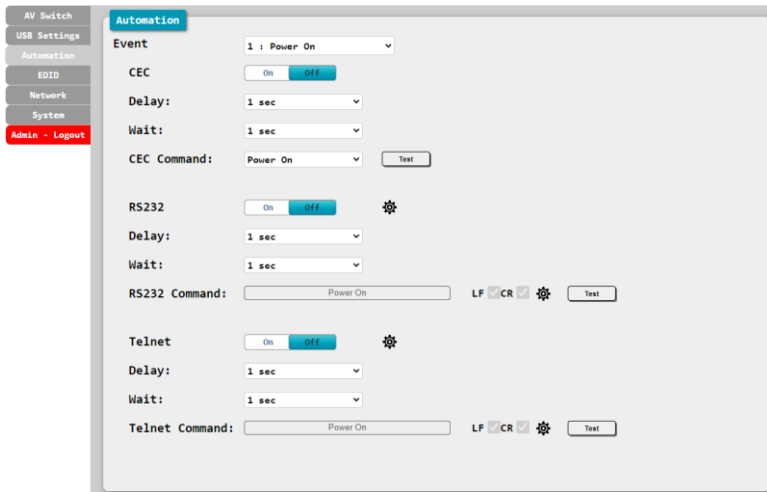

- 1) **Event:** Use the dropdown to select the Automation Event to configure. Available Automation Events are:
 - **Power On:** This unit is powered on.
 - **Out A Source Active:** The currently selected input changes from inactive to active.
 - **Out A Source Lost:** The currently selected input changes from active to inactive.
- 2) **CEC:** Enable or disable sending a CEC command when the currently selected Automation Event is activated.

Note: CEC support must also be enabled on the device connected to HDMI output A.

Delay: Set the length of time, in seconds, that the specified Automation Event must continue to be true before sending the defined CEC command.

Wait: Set the length of time, in seconds, to wait after this Automation Event has been activated before ANY other Automation Event can be detected.

CEC Command: Set the CEC command to send when the specified Automation Event is activated. Click the “Test” button to send the command immediately. Available CEC commands are:

- **Power Off:** Turn off the connected HDMI display device.
- **Power On:** Turn on the connected HDMI display device.
- **Active Source:** Force the connected HDMI display device to switch to the HDMI input that this unit is connected to.

Note: Not all HDMI devices support all CEC commands.

- 3) **RS-232:** Enable or disable sending an RS-232 command when the currently selected Automation Event is activated. Click the “Edit” icon (⚙️) to configure the RS-232 port.

Note: RS-232 Automation commands will only be output over the “CTL” RS-232 port.

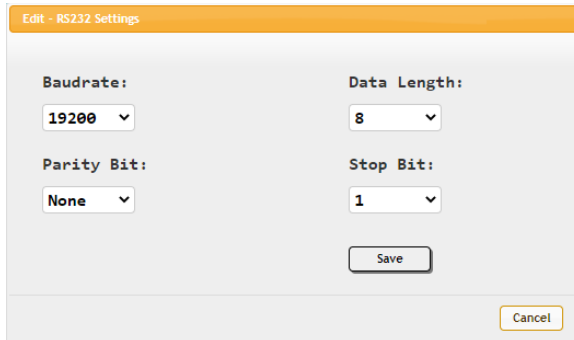

Delay: Set the length of time, in seconds, that the specified Automation Event must continue to be true before sending the defined RS-232 command.

Wait: Set the length of time, in seconds, to wait after this Automation Event has been activated before ANY other Automation Event can be detected.

RS232 Command: Click the Edit icon (⚙️) to define the RS-232 command to send when the specified Automation Event is activated. Click the “Test” button to send the command immediately.

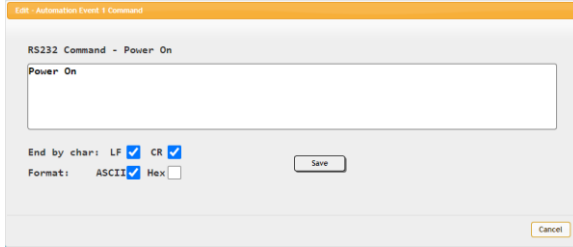

- 4) **Telnet:** Enable or disable sending a Telnet command to the designated IP address when the currently selected Automation Event is activated. Click the “Edit” icon (✎) to configure the target IP address and communication port. If the target Telnet device requires a login to receive commands, those details may be added as well.

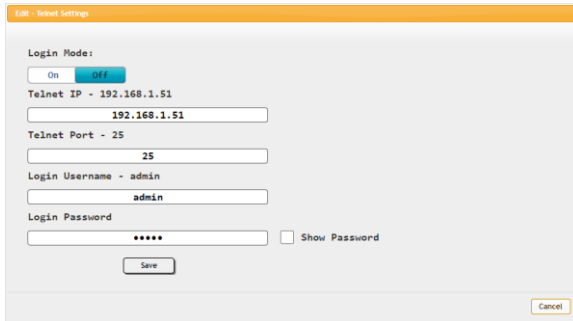

Delay: Set the length of time, in seconds, that the specified Automation Event must continue to be true before sending the defined Telnet command.

Wait: Set the length of time, in seconds, to wait after this Automation Event has been activated before ANY other Automation Event can be detected.

Telnet Command: Click the Edit icon (✎) to define the Telnet command to send when the specified Automation Event is activated. Click the “Test” button to send the command immediately.

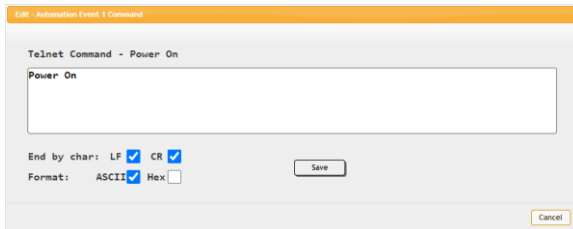

6.4.4 EDID Tab

This tab provides control over the EDID settings of all inputs. This unit provides the option of six standard EDIDs, two sink sourced EDIDs and three user uploaded EDIDs that can be assigned to one input or all inputs as a group. The names of the user uploaded EDIDs can be changed if desired.

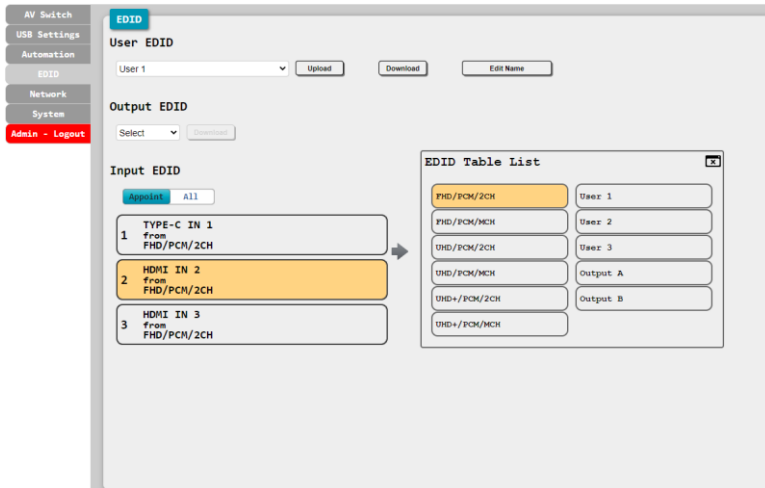

1) User EDID

Upload: To upload a User EDID, select the User EDID slot to upload into from the dropdown list and then click the “Upload” button. An EDID Upload window will appear, allowing you to locate and upload the preferred EDID file (*.bin format) from a local PC. Once the correct file has been selected, please click the “Upload” button in the window, and the file will be transferred to the unit.

Download: To save an existing User EDID to your local PC, select the User EDID slot from the dropdown list and then press the “Download” button. Depending on your browser settings you will either be asked where to save the downloaded file, or the file will be transferred to the default download location on your PC.

Edit Name: Click the “Edit Name” button to open a window that allows changing the name of the User EDID. Click the “Save Change” button within the window to confirm the change.

2) Output EDID

Download: To save the EDID from a connected display to your local PC, select the output from the dropdown list then press the “Download” button. Depending on your browser settings you will either be asked where to save the downloaded file, or the file will be transferred to the default download location on your PC.

3) Input EDID

Appoint/All: The Input EDID section allows for the assignment of an EDID to each individual input port, or to all inputs at once. Click the selection bar to toggle between “Appoint” (individual assignment), or “All” inputs.

EDID Selection: Click on one or more input buttons to open the EDID Table List window. Select the new EDID source to use, from the choices on the right, and the change will occur immediately across all selected Inputs.

This unit provides the following 6 default EDIDs:

Unit's default EDIDs	
FHD/PCM/2CH	1920×1080p@60Hz (4.95Gbps) & 8-bit color, LPCM 2.0
FHD/PCM/MCH	1920×1080p@60Hz (4.95Gbps) & 8-bit color, LPCM 7.1
UHD/PCM/2CH	3840×2160p@30Hz (10.2Gbps) & Deep Color (8/10/12-bit), LPCM 2.0
UHD/PCM/MCH	3840×2160p@30Hz (10.2Gbps) & Deep Color (8/10/12-bit), LPCM 7.1
UHD+/PCM/2CH	3840×2160p@60Hz (18Gbps) & Deep Color (8/10/12-bit), LPCM 2.0
UHD+/PCM/MCH	3840×2160p@60Hz (18Gbps) & Deep Color (8/10/12-bit), LPCM 7.1

Note: In some rare cases it is possible for custom or external EDIDs to cause compatibility issues with certain sources. If this happens, it is recommended to switch to one of the 6 default EDIDs for maximum compatibility.

6.4.5 Network Tab

This tab provides network configuration options including changing the IP mode, viewing/setting the IP configuration, changing the admin login password, and changing the Web Login timeout.

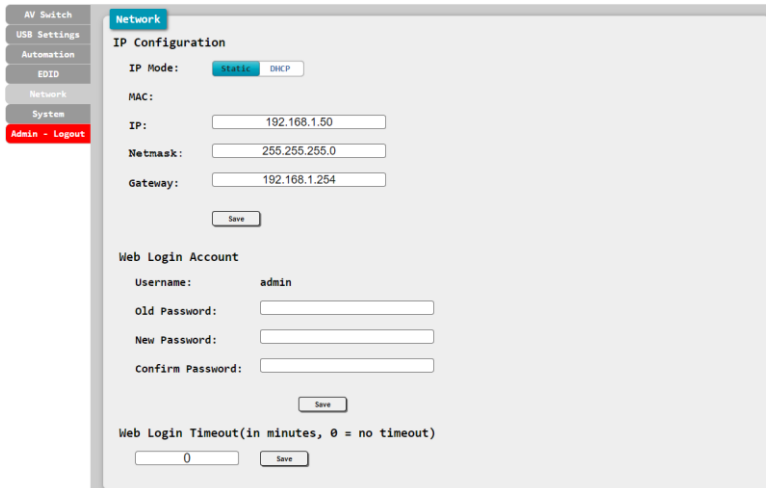

- 1) **IP Configuration:** IP Mode may be switched between Static IP or DHCP. In Static IP Mode the IP, netmask and gateway addresses may be manually set. When in DHCP Mode, the unit will attempt to connect to a local DHCP server and obtain IP, netmask and gateway addresses automatically. Please press “Save” after making any changes to the IP configuration or mode.

Note: If the IP address is changed then the IP address required for WebGUI/Telnet access will also change accordingly.

- 2) **Web Login Account:** The WebGUI admin password can be changed here. Please press “Save” after entering the old and new passwords to enact the change.

Note: The default password is “admin”.

- 3) **Web Login Timeout:** Select the length of time to wait before logging the user out of the WebGUI due to inactivity. Available range is from 0 to 35790 minutes. Setting it to 0 will disable the timeout function.

6.4.6 System Tab

This tab provides serial number information, system configuration backup/restore/reset, system reboot, and firmware update functions.

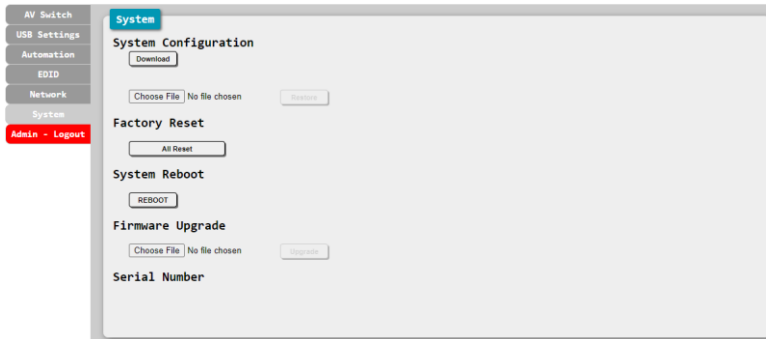

1) System Configuration

Download: The current system configuration, including routing and settings, may be saved as an XML file to a PC. Click the “Download” button to save the current system configuration to your local PC.

Restore: Previously saved system configurations may be restored from a saved XML file. Click the “Choose File” button to locate the saved XML file, then click the “Restore” button to upload and activate the selected configuration.

- 2) **Factory Reset:** Press the “ALL Reset” button to reset the unit to its factory default state. After the reset is complete, the unit will reboot automatically.
- 3) **System Reboot:** Click this button to reboot the unit.
- 4) **Firmware Upgrade:** To update the unit’s firmware, click the “Choose File” button to open the file selection window and then select the firmware update file (*.bin format) located on your local PC. After selecting the file, click the “Upgrade” button to begin the firmware update process. After the upgrade is complete, the unit will reboot automatically.
- 5) **Serial Number:** Displays the unit’s serial number.

6.5 Telnet Control

Before attempting to use Telnet control, please ensure that both the unit and the PC are connected to the same active networks.

Start your preferred Telnet/Console client, or use the built in client provided by most modern computer operating systems. After starting the client, connect by using the current IP address of the unit and port 23 (if the communication port number used by the unit has not been changed previously). This will connect us to the unit we wish to control and commands may now be entered directly.

Note 1: If the IP address of the unit is changed then the IP address required for Telnet access will also change accordingly.

Note 2: The default IP address is 192.168.1.50 and the default communication port is 23.

6.6 Serial and Telnet Commands

COMMAND	
Description and Parameters	
help	Show the full command list.
help N1	Show details about the specified command. N1 = {command}
?	Show the full command list.
? N1	Show details about the specified command. N1 = {command}
get fw ver	Show the unit's current firmware version.
get command ver	Show the unit's current command version

COMMAND
Description and Parameters
get mac addr Show the unit's MAC address.
get model name Show the unit's model name.
get model type Show the unit's product type.
get user config List the unit's current configuration information.
set system reboot Reboot the unit.
set keylock N1 Enable or disable the front panel key lock. Available values for N1 : ON [Front panel buttons locked] OFF [Front panel buttons unlocked]
get keylock Show the current front panel lock state.
set factory default Reset the unit to the factory defaults.
set factory ipconfig default Reset the unit's network settings to the factory defaults.
set factory out route default Reset the unit's routing to the factory defaults.
set feedback broadcast N1 Enable or disable the broadcast of console command feedback. Available values for N1 : ON [Enabled] OFF [Disabled]

COMMAND	
Description and Parameters	
get feedback broadcast	Show the current console command feedback broadcast state.
get update filename	Show the unit's update firmware filename.
set system usb fw update	Trigger the unit's firmware update state and load the new firmware file via USB.
set nickname N1	Set the unit's nickname. N1 = {ASCII string} [Unit's nickname]
get nickname	Show the unit's current nickname.
set uart N1 reset	Reset the settings of the specified RS-232 port to the factory defaults. Available values for N1 : 1 [CTL port] 2 [CLI port]
set uart N1 baudrate N2	Set the baud rate of the specified RS-232 port. Available values for N1 : 1 [CTL port] 2 [CLI port] Available values for N2 : 4800 [4800 baud] 9600 [9600 baud] 19200 [19200 baud] 38400 [38400 baud] 57600 [57600 baud] 115200 [115200 baud]

COMMAND**Description and Parameters****get uart N1 baudrate**

Show the current baud rate of the specified RS-232 port.

Available values for **N1**:

- 1 [CTL port]
- 2 [CLI port]

set uart N1 stop bit N2

Set the number of stop bits for the specified RS-232 port.

Available values for **N1**:

- 1 [CTL port]
- 2 [CLI port]

N2 = 1~2 [Stop bits]

get uart N1 stop bit

Show the current number of stop bits of the specified RS-232 port.

Available values for **N1**:

- 1 [CTL port]
- 2 [CLI port]

set uart N1 data bit N2

Set the data bits for the specified RS-232 port.

Available values for **N1**:

- 1 [CTL port]
- 2 [CLI port]

N2 = 5~8 [Data bits]

get uart N1 data bit

Show the current number of data bits of the specified RS-232 port.

Available values for **N1**:

- 1 [CTL port]
- 2 [CLI port]

COMMAND	
Description and Parameters	
set uart N1 parity N2	<p>Set the parity of the specified RS-232 port</p> <p>Available values for N1:</p> <p>1 [CTL port] 2 [CLI port]</p> <p>Available values for N2:</p> <p>0 [None] 1 [Odd] 2 [Even]</p>
get uart N1 parity	<p>Show the current parity setting of the specified RS-232 port.</p> <p>Available values for N1:</p> <p>1 [CTL port] 2 [CLI port]</p>
set ip mode N1	<p>Set the unit's IP address assignment mode.</p> <p>Available values for N1:</p> <p>STATIC [Static IP mode] DHCP [DHCP mode]</p>
get ip mode	<p>Show the current IP address assignment mode.</p>
get ipconfig	<p>Show the unit's current IP configuration information.</p>
get ipaddr	<p>Show the unit's current IP address.</p>
get netmask	<p>Show the unit's current netmask.</p>
get gateway	<p>Show the unit's current gateway address.</p>

COMMAND	
Description and Parameters	
set static ipaddr N1	Set the unit's static IP address. N1 = X.X.X.X [X = 0~255, IP address]
get static ipaddr	Show the unit's current static IP address.
set static netmask N1	Set the unit's static netmask. N1 = X.X.X.X [X = 0~255, Netmask]
get static netmask	Show the unit's current static netmask.
set static gateway N1	Set the unit's static gateway address. N1 = X.X.X.X [X = 0~255, Gateway address]
get static gateway	Show the unit's current static gateway address.
set webgui password N1	Set the WebGUI login password. N1 = {ASCII string} [WebGUI password]
set telnet login N1	Enable or disable requiring a login for Telnet. Available values for N1 : ON [Login required] OFF [No login required]
get telnet login	Show the current state of the Telnet login requirement.
set telnet username N1	Set the Telnet login username. N1 = {ASCII string} [Telnet login username]

COMMAND
Description and Parameters
get telnet username Show the current Telnet login username.
set telnet password N1 Set the Telnet login password. N1 = {ASCII string} [Telnet password]
get webgui login timeout Show the current WebGUI inactivity timeout value.
set in N1 name N2 Set the name of the specified input. Available values for N1 : 1 [USB-C input] 2 [HDMI input 1] 3 [HDMI input 2] N2 = {ASCII string} [Input name]
get in N1 name Show the current name of the specified input. Available values for N1 : 1 [USB-C input] 2 [HDMI input 1] 3 [HDMI input 2]
set out N1 name N2 Set the name of the specified output. Available values for N1 : A [HDMI output A] B [HDMI output B] N2 = {ASCII string} [Output name]

COMMAND**Description and Parameters****get out N1 name**

Show the name of the specified output.

Available values for **N1**:

- A [HDMI output A]
- B [HDMI output B]

set out N1 route N2

Route the specified input to the specified output.

Available values for **N1**:

- A [HDMI output A]
- B [HDMI output B]

Available values for **N2**:

- 1 [USB-C input]
- 2 [HDMI input 1]
- 3 [HDMI input 2]

get out N1 route

Show which input is currently routed to the specified output.

Available values for **N1**:

- A [HDMI output A]
- B [HDMI output B]

get in N1 hactive

Show the horizontal active pixel value of the specified input's current video source.

Available values for **N1**:

- 1 [USB-C input]
- 2 [HDMI input 1]
- 3 [HDMI input 2]

get in N1 vactive

Show the vertical active pixel value of the specified input's current video source.

Available values for **N1**:

- 1 [USB-C input]
- 2 [HDMI input 1]
- 3 [HDMI input 2]

COMMAND

Description and Parameters

get in N1 refresh rate

Show the refresh rate of the specified input's current video source.

Available values for **N1**:

- 1 [USB-C input]
- 2 [HDMI input 1]
- 3 [HDMI input 2]

get in N1 interlace

Show the interlace state of the specified input's current video source.

Available values for **N1**:

- 1 [USB-C input]
- 2 [HDMI input 1]
- 3 [HDMI input 2]

Possible response values:

- 0 [Not interlaced]
- 1 [Interlaced]

set in N1 hdcp mode N2

Set the HDCP behavior of the specified input.

Available values for **N1**:

- 1 [USB-C input]
- 2 [HDMI input 1]
- 3 [HDMI input 2]

Available values for **N2**:

- 0 [HDCP disabled]
- 1 [Follow source]
- 2 [Follow display]

get in N1 hdcp mode

Show the current HDCP behavior used by the specified input.

Available values for **N1**:

- 1 [USB-C input]
- 2 [HDMI input 1]
- 3 [HDMI input 2]

COMMAND**Description and Parameters****get in N1 hdcp status**

Show the current HDCP status of the specified input.

Available values for **N1**:

- 1 [USB-C input]
- 2 [HDMI input 1]
- 3 [HDMI input 2]

Possible response values:

- 0 [No HDCP]
- 1 [HDCP 1.x active]
- 2 [HDCP 2.2 active]

get out N1 hdcp status

Show the current HDCP status of the specified output.

Available values for **N1**:

- A [HDMI output A]
- B [HDMI output B]

Possible response values:

- 0 [No HDCP]
- 1 [HDCP 1.x active]
- 2 [HDCP 2.2 active]

get out N1 hdcp ability

Show the HDCP compliance level of the display device connected to the specified output.

Available values for **N1**:

- A [HDMI output A]
- B [HDMI output B]

Possible response values:

- 0 [No HDCP support]
- 1 [HDCP 1.x supported]
- 2 [HDCP 2.2 supported]

COMMAND	
Description and Parameters	
get in N1 hdcp ability	<p>Show the HDCP compliance level of the source connected to the specified input.</p> <p>Available values for N1:</p> <ul style="list-style-type: none"> 1 [USB-C input] 2 [HDMI input 1] 3 [HDMI input 2] <p>Possible response values:</p> <ul style="list-style-type: none"> 0 [No HDCP support] 1 [HDCP 1.x supported] 2 [HDCP 2.2 supported]
set out auto mode N1	<p>Set the auto switching behavior of the unit.</p> <p>Available values for N1:</p> <ul style="list-style-type: none"> 0 [Auto switching disabled] 1 [Auto switching enabled]
get out auto mode	<p>Show the current auto switching mode of the unit.</p>
get in N1 sync status	<p>Show the current sync state of the specified input.</p> <p>Available values for N1:</p> <ul style="list-style-type: none"> 1 [USB-C input] 2 [HDMI input 1] 3 [HDMI input 2] <p>Possible response values:</p> <ul style="list-style-type: none"> 0 [No sync detected] 1 [Sync active]

COMMAND	
Description and Parameters	
get out N1 sync status	
Show the current sync state of the specified output.	
Available values for N1 :	
A	[HDMI output A]
B	[HDMI output B]
Possible response values:	
0	[No sync detected]
1	[Sync active]
set out A 4k2k downscale mode N1	
Set the 4K to 1080p downscale behavior used by output A.	
Available values for N1 :	
0	[4K pass-through]
1	[Auto mode]
2	[4K to 1080p mode]
get out A 4k2k downscale mode	
Show the current 4K to 1080p downscale behavior for output A.	
set in N1 edid N2	
Set the EDID to use on the specified input.	
Available values for N1 :	
1	[USB-C input]
2	[HDMI input 1]
3	[HDMI input 2]
Available values for N2 :	
1	[FHD/PCM/2CH]
2	[FHD/PCM/MCH]
3	[UHD/PCM/2CH]
4	[UHD/PCM/MCH]
5	[UHD+/PCM/2CH]
6	[UHD+/PCM/MCH]
7	[User EDID 1]
8	[User EDID 2]
9	[User EDID 3]
10	[Output A's EDID]
11	[Output B's EDID]

COMMAND	
Description and Parameters	
get in N1 edid	<p>Show the EDID currently being used on the specified input.</p> <p>Available values for N1:</p> <ul style="list-style-type: none"> 1 [USB-C input] 2 [HDMI input 1] 3 [HDMI input 2]
get in edid list	<p>List all available EDID selections.</p>
set edid N1 name N2	<p>Set the name for the specified EDID. (Only User EDIDs may be renamed)</p> <p>Available values for N1:</p> <ul style="list-style-type: none"> 7 [User EDID 1] 8 [User EDID 2] 9 [User EDID 3] <p>N2 = {ASCII string} [User EDID name]</p>
get edid N1 name	<p>Show the name for the specified EDID.</p> <p>N1 = 1~11 [EDID number]</p>
set user N1 edid data N2	<p>Upload a new EDID (in hex format) for use as the specified User EDID.</p> <p>N1 = 1~3 [User EDID number]</p> <p>N2 = {EDID data} [Comma delimited hex pairs]</p>
get user N1 edid data	<p>Show the current contents of the specified User EDID as hex data.</p> <p>N1 = 1~3 [User EDID number]</p>

COMMAND**Description and Parameters****get sink N1 edid data**

Show the EDID from the display connected to the specified output as hex data.

Available values for **N1**:

- A [HDMI output A]
- B [HDMI output B]

get in N1 edid data

Show the EDID currently used by the specified input as hex data.

Available values for **N1**:

- 1 [USB-C input]
- 2 [HDMI input 1]
- 3 [HDMI input 2]

get internal N1 edid data

Show the specified Internal EDID as hex data.

N1 = 1~6 [Internal EDID number]

get all in edid list

List the EDIDs assigned to all inputs.

set all in edid mode N1

Select the EDID management mode to use (All or Appoint) for all inputs.

Available values for **N1**:

- 1 [All mode]
- 2 [Appoint mode]

get all in edid mode

Show the current EDID management mode used by all inputs.

COMMAND																							
Description and Parameters																							
set all in edid N1	<p>Set the EDID to use when the “All” EDID mode is active.</p> <p>Available values for N1:</p> <table border="0"> <tr><td>1</td><td>[FHD/PCM/2CH]</td></tr> <tr><td>2</td><td>[FHD/PCM/MCH]</td></tr> <tr><td>3</td><td>[UHD/PCM/2CH]</td></tr> <tr><td>4</td><td>[UHD/PCM/MCH]</td></tr> <tr><td>5</td><td>[UHD+/PCM/2CH]</td></tr> <tr><td>6</td><td>[UHD+/PCM/MCH]</td></tr> <tr><td>7</td><td>[User EDID 1]</td></tr> <tr><td>8</td><td>[User EDID 2]</td></tr> <tr><td>9</td><td>[User EDID 3]</td></tr> <tr><td>10</td><td>[Output A's EDID]</td></tr> <tr><td>11</td><td>[Output B's EDID]</td></tr> </table>	1	[FHD/PCM/2CH]	2	[FHD/PCM/MCH]	3	[UHD/PCM/2CH]	4	[UHD/PCM/MCH]	5	[UHD+/PCM/2CH]	6	[UHD+/PCM/MCH]	7	[User EDID 1]	8	[User EDID 2]	9	[User EDID 3]	10	[Output A's EDID]	11	[Output B's EDID]
1	[FHD/PCM/2CH]																						
2	[FHD/PCM/MCH]																						
3	[UHD/PCM/2CH]																						
4	[UHD/PCM/MCH]																						
5	[UHD+/PCM/2CH]																						
6	[UHD+/PCM/MCH]																						
7	[User EDID 1]																						
8	[User EDID 2]																						
9	[User EDID 3]																						
10	[Output A's EDID]																						
11	[Output B's EDID]																						
get all in edid	<p>Show the current EDID used by the “All” EDID mode.</p>																						
get internal edid number	<p>Show the total number of internal EDIDs in the unit.</p>																						
get user edid number	<p>Show the total number of user EDIDs in the unit.</p>																						
get sink edid number	<p>Show the total number of sink EDIDs in the unit.</p>																						
set audio out A mute N1	<p>Enable or disable muting the analog audio output.</p> <p>Available values for N1:</p> <table border="0"> <tr><td>ON</td><td>[Mute]</td></tr> <tr><td>OFF</td><td>[Unmute]</td></tr> </table>	ON	[Mute]	OFF	[Unmute]																		
ON	[Mute]																						
OFF	[Unmute]																						
get audio out A mute	<p>Show the current mute state of the analog audio output.</p>																						

COMMAND	
Description and Parameters	
set audio out A route N1	<p>Route the specified audio source to the analog audio output.</p> <p>Available values for N1:</p> <p>1 [HDMI output A] 2 [HDMI output B]</p>
get audio out A route	<p>Show the current audio input routed to the specified audio output.</p>
set usb host auto mode N1	<p>Set the automatic USB host switching behavior of the unit.</p> <p>Available values for N1:</p> <p>ON [Auto switching enabled] OFF [Auto switching disabled]</p>
get usb host auto mode	<p>Show the current automatic USB switching mode of the unit.</p>
set usbc 1 3.0 mode N1	<p>Enable or disable USB 3.0 “Super Speed” support on the USB-C port.</p> <p>Available values for N1:</p> <p>ON [Super Speed support enabled] OFF [Super Speed support disabled]</p>
get usbc 1 3.0 mode	<p>Show the current USB 3.0 “Super Speed” support state for the USB-C port.</p>
set automation event N1 uart A N2	<p>Enable or disable the specified Automation Event’s RS-232 response.</p> <p>Available values for N1:</p> <p>1 [Power on] 2 [Out A source active] 3 [Out A source lost]</p> <p>Available values for N2:</p> <p>ON [Enable] OFF [Disable]</p>

COMMAND

Description and Parameters

get automation event N1 uart A

Show the current state of the specified Automation Event's RS-232 response.

Available values for **N1**:

- 1 [Power on]
- 2 [Out A source active]
- 3 [Out A source lost]

set automation event N1 uart A command N2

Set the RS-232 command string to send when the specified Automation Event is activated.

Available values for **N1**:

- 1 [Power on]
- 2 [Out A source active]
- 3 [Out A source lost]

N2 = {ASCII text} [Command string]

get automation event N1 uart A command

Show the RS-232 command string to be sent when the specified Automation Event is activated.

Available values for **N1**:

- 1 [Power on]
- 2 [Out A source active]
- 3 [Out A source lost]

set automation event N1 uart A delay N2

Set the delay time that the specified Automation Event must continue to be true before sending the defined RS-232 command.

Available values for **N1**:

- 1 [Power on]
- 2 [Out A source active]
- 3 [Out A source lost]

N2 = 0~240 [Delay in seconds]

COMMAND**Description and Parameters****get automation event N1 uart A delay**

Show the delay time for the specified Automation Event's RS-232 response.

Available values for **N1**:

- 1 [Power on]
- 2 [Out A source active]
- 3 [Out A source lost]

set automation event N1 uart A wait N2

Set the length of time to wait after an Automation Event's RS-232 response has been activated before ANY other Automation Event can be detected.

Available values for **N1**:

- 1 [Power on]
- 2 [Out A source active]
- 3 [Out A source lost]

N2 = 0~240 [Wait in seconds]

get automation event N1 uart A wait

Show the wait time for the specified Automation Event's RS-232 response.

Available values for **N1**:

- 1 [Power on]
- 2 [Out A source active]
- 3 [Out A source lost]

set automation event N1 uart A endchar N2

Set the termination character(s) to attach to the end of the specified Automation Event's RS-232 command string when it is sent.

Available values for **N1**:

- 1 [Power on]
- 2 [Out A source active]
- 3 [Out A source lost]

Available values for **N2**:

- 0 [None]
- 1 [Carriage return]
- 2 [Linefeed]
- 3 [Carriage return + Linefeed]

COMMAND

Description and Parameters

get automation event N1 uart A endchar

Show the current termination character(s) used by the specified Automation Event's RS-232 command string.

Available values for **N1**:

- 1 [Power on]
- 2 [Out A source active]
- 3 [Out A source lost]

set automation event N1 uart A command format N2

Set the string format to use for the specified Automation Event's RS-232 command string when it is sent.

Available values for **N1**:

- 1 [Power on]
- 2 [Out A source active]
- 3 [Out A source lost]

Available values for **N2**:

- 0 [ASCII]
- 1 [Hex]

get automation event N1 uart A command format

Show the current string format used by the specified Automation Event's RS-232 command string.

Available values for **N1**:

- 1 [Power on]
- 2 [Out A source active]
- 3 [Out A source lost]

set automation event N1 uart A test command

Trigger sending the specified Automation Event's currently defined RS-232 command string.

Available values for **N1**:

- 1 [Power on]
- 2 [Out A source active]
- 3 [Out A source lost]

COMMAND**Description and Parameters****set automation event N1 cec A N2**

Enable or disable the specified Automation Event's CEC response.

Available values for **N1**:

- 1 [Power on]
- 2 [Out A source active]
- 3 [Out A source lost]

Available values for **N2**:

- ON [Enable]
- OFF [Disable]

get automation event N1 cec A

Show the current state of the specified Automation Event's CEC response.

Available values for **N1**:

- 1 [Power on]
- 2 [Out A source active]
- 3 [Out A source lost]

set automation event N1 cec A delay N2

Set the delay time that the specified Automation Event must continue to be true before sending the defined CEC command.

Available values for **N1**:

- 1 [Power on]
- 2 [Out A source active]
- 3 [Out A source lost]

N2 = 0~240 [Delay in seconds]

get automation event N1 cec A delay

Show the delay time for the specified Automation Event's CEC response.

Available values for **N1**:

- 1 [Power on]
- 2 [Out A source active]
- 3 [Out A source lost]

COMMAND

Description and Parameters

set automation event N1 cec A wait N3

Set the length of time to wait after an Automation Event's CEC response has been activated before ANY other Automation Event can be detected.

Available values for **N1**:

- 1 [Power on]
- 2 [Out A source active]
- 3 [Out A source lost]

N2 = 0~240 [Wait in seconds]

get automation event N1 cec A wait

Show the wait time for the specified Automation Event's CEC response.

Available values for **N1**:

- 1 [Power on]
- 2 [Out A source active]
- 3 [Out A source lost]

set automation event N1 cec A test command

Trigger sending the specified Automation Event's currently defined CEC command string.

Available values for **N1**:

- 1 [Power on]
- 2 [Out A source active]
- 3 [Out A source lost]

set automation event N1 telnet A N2

Enable or disable the specified Automation Event's Telnet response.

Available values for **N1**:

- 1 [Power on]
- 2 [Out A source active]
- 3 [Out A source lost]

Available values for **N2**:

- ON [Enable]
- OFF [Disable]

COMMAND**Description and Parameters****get automation event N1 telnet A**

Show the current state of the specified Automation Event's Telnet response.

Available values for **N1**:

- 1 [Power on]
- 2 [Out A source active]
- 3 [Out A source lost]

set automation event N1 telnet A command N2

Set the Telnet command string to send when the specified Automation Event is activated.

Available values for **N1**:

- 1 [Power on]
- 2 [Out A source active]
- 3 [Out A source lost]

N2 = {ASCII text} [Command string]

get automation event N1 telnet A command

Show the Telnet command string to be sent when the specified Automation Event is activated.

Available values for **N1**:

- 1 [Power on]
- 2 [Out A source active]
- 3 [Out A source lost]

set automation event N1 telnet A delay N2

Set the delay time that the specified Automation Event must continue to be true before sending the defined Telnet command.

Available values for **N1**:

- 1 [Power on]
- 2 [Out A source active]
- 3 [Out A source lost]

N2 = 0~240 [Delay in seconds]

COMMAND

Description and Parameters

get automation event N1 telnet A delay

Show the delay time for the specified Automation Event's Telnet response.

Available values for **N1**:

- 1 [Power on]
- 2 [Out A source active]
- 3 [Out A source lost]

set automation event N1 telnet A wait N2

Set the length of time to wait after an Automation Event's Telnet response has been activated before ANY other Automation Event can be detected.

Available values for **N1**:

- 1 [Power on]
- 2 [Out A source active]
- 3 [Out A source lost]

N2 = 0~240 [Wait in seconds]

get automation event N1 telnet A wait

Show the wait time for the specified Automation Event's Telnet response.

Available values for **N1**:

- 1 [Power on]
- 2 [Out A source active]
- 3 [Out A source lost]

set automation event N1 telnet A command format N2

Set the string format to use for the specified Automation Event's Telnet command string when it is sent.

Available values for **N1**:

- 1 [Power on]
- 2 [Out A source active]
- 3 [Out A source lost]

Available values for **N2**:

- 0 [ASCII]
- 1 [Hex]

COMMAND**Description and Parameters****get automation event N1 telnet A command format**

Show the current string format used by the specified Automation Event's Telnet command string.

Available values for **N1**:

- 1 [Power on]
- 2 [Out A source active]
- 3 [Out A source lost]

set automation event N1 telnet A test command

Trigger sending the specified Automation Event's currently defined Telnet command string.

Available values for **N1**:

- 1 [Power on]
- 2 [Out A source active]
- 3 [Out A source lost]

set automation telnet A login N1

Enable or disable allowing automated Telnet logins.

Available values for **N1**:

- ON [Enabled]
- OFF [Disabled]

get automation telnet A login

Show the current state of automated Telnet login allowance.

set automation telnet A username N1

Set the automated Telnet login username.

N1 = {ASCII string} [Username]

get automation telnet A username

Show the current automated Telnet login username.

set automation telnet A password N1

Set the automated Telnet login password.

N1 = {ASCII string} [Password]

COMMAND	
Description and Parameters	
get automation telnet A password	Show the current automated Telnet login password.
set automation telnet A port N1	Set the network port to use when sending Telnet Automation Event commands. N1 = 1~65535 [Network port number]
get automation telnet A port	Show the current network port used when sending Telnet Automation Event commands.
set automation telnet A remote ipaddr N1	Set the remote network IP address to use when sending Telnet Automation Event commands. N1 = X.X.X.X [X = 0~255, IP address]
get automation telnet A remote ipaddr	Show the current remote network IP address used when sending Telnet Automation Event commands.

Note: Commands will not be executed unless followed by a carriage return. Commands are not case-sensitive.

7. CONNECTION DIAGRAM

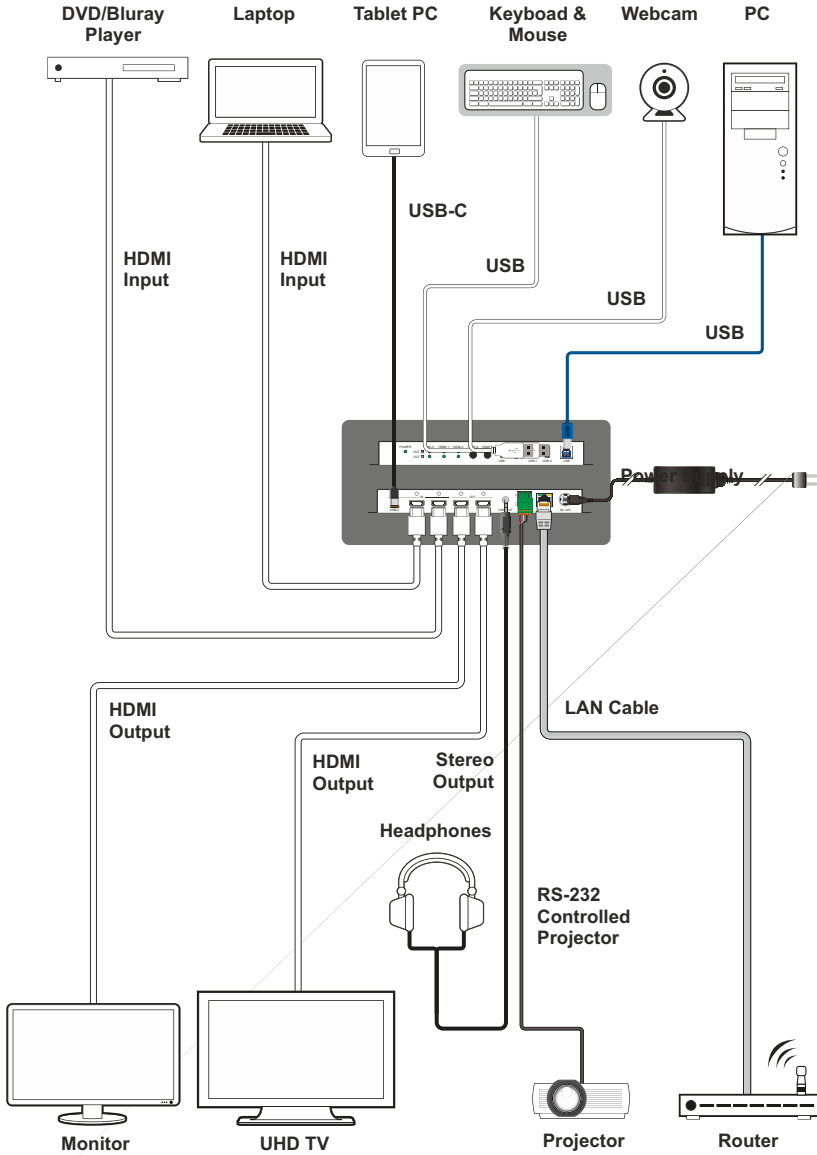

8. SPECIFICATIONS

8.1 Technical Specifications

HDMI Bandwidth	18Gbps
USB-C Bandwidth	21.6Gbps
Input Ports	2×HDMI (Type-A) 1×USB 3.0 (Type-C)
Output Ports	2×HDMI (Type-A) 1×Stereo Audio (3.5mm) 1×RS-232 (4-pin Terminal Block)
Pass-through Ports	1×USB 3.0 (Type-A) 1×USB 3.0 (Type-B)
Pass-through/Service Port	1×USB 3.0 (Type-A)
Control Ports	1×IP Control (RJ-45) 1×RS-232 (4-pin Terminal Block)
Baud Rate	Up to 115200 (19200 Control)
Power Supply	24V/5A DC (US/EU standards, CE/FCC/UL certified)
ESD Protection (HBM)	±8kV (Air Discharge) ±4kV (Contact Discharge)
Dimensions (W×H×D)	213.5mm×25mm×108mm [Case Only] 213.5mm×25mm×112.5mm [All Inclusive]
Weight	690g
Chassis Material	Metal (Steel)
Chassis Color	Black
Operating Temperature	0°C – 40°C/32°F – 104°F
Storage Temperature	-20°C – 60°C/-4°F – 140°F
Relative Humidity	20 – 90% RH (Non-condensing)
Power Consumption	67.68W

8.2 Video Specifications

Supported Resolutions (Hz)	Input		Output
	HDMI	USB-C	HDMI
720×400p@70/85			
640×480p@60/72/75/85			
720×480i@60			
720×480p@60			
720×576i@50			
720×576p@50			
800×600p@56/60/72/75/85			
848×480p@60			
1024×768p@60/70/75/85			
1152×864p@75			
1280×720p@50/60			
1280×768p@60/75/85			
1280×800p@60/75/85			
1280×960p@60/85			
1280×1024p@60/75/85			
1360×768p@60			
1366×768p@60			
1400×1050p@60			
1440×900p@60/75			
1600×900p@60RB			
1600×1200p@60			
1680×1050p@60			
1920×1080i@50/60			
1920×1080p@24/25/30			
1920×1080p@50/60			
1920×1200p@60RB			

Supported Resolutions (Hz)	Input		Output
	HDMI	USB-C	HDMI
2560×1440p@60RB			
2560×1600p@60RB			
2048×1080p@24/25/30			
2048×1080p@50/60			
3840×2160p@24/25/30			
3840×2160p@50/60 (4:2:0)			
3840×2160p@24, HDR10			
3840×2160p@50/60 (4:2:0), HDR10			
3840×2160p@50/60			
4096×2160p@24/25/30			
4096×2160p@50/60 (4:2:0)			
4096×2160p@24, HDR10			
4096×2160p@50/60 (4:2:0), HDR10			
4096×2160p@50/60			

8.3 Audio Specifications

8.3.1 Digital Audio

HDMI & USB-C Input / HDMI Output	
LPCM	
Max Channels	8 Channels
Sampling Rate (kHz)	32, 44.1, 48, 88.2, 96, 176.4, 192
Bitstream	
Supported Formats	Standard & High-Definition

8.3.2 Analog Audio

Analog Output	
Max Audio Level	2Vrms
THD+N	< -84dB@0dBFS 1kHz (A-wt)
SNR	> 104dB@0dBFS
Frequency Response	< ±0.5dB@20Hz~20kHz
Crosstalk	< -76dB@10kHz
Impedance	500Ω
Type	Unbalanced

8.4 Cable Specifications

Cable Length	1080p		4K30	4K60
	8-bit	12-bit	(4:4:4) 8-bit	(4:4:4) 8-bit
High Speed HDMI Cable				
HDMI Input	15m	10m	5m	3m
HDMI Output	15m	10m	5m	3m
USB-C Cable				
USB-C Input	2m			

Bandwidth Category Examples:

- **1080p (FHD Video)**
 - Up to 1080p@60Hz, 12-bit color
 - Data rates lower than 5.3Gbps or below 225MHz TMDS clock
- **4K30 (4K UHD Video)**
 - 4K@24/25/30Hz & 4K@50/60Hz (4:2:0), 8-bit color
 - Data rates higher than 5.3Gbps or above 225MHz TMDS clock but below 10.2Gbps
- **4K60 (4K UHD+ Video)**
 - 4K@50/60Hz (4:4:4, 8-bit)
 - 4K@50/60Hz (4:2:0, 10-bit HDR)
 - Data rates higher than 10.2Gbps

9. ACRONYMS

ACRONYM	COMPLETE TERM
ASCII	American Standard Code for Information Interchange
AV	Audio/Video
Cat.5e	Enhanced Category 5 cable
Cat.6	Category 6 cable
Cat.6A	Augmented Category 6 cable
Cat.7	Category 7 cable
CEC	Consumer Electronics Control
CLI	Command-Line Interface
DAC	Digital-to-Analog Converter
dB	Decibel
DHCP	Dynamic Host Configuration Protocol
DVI	Digital Visual Interface
EDID	Extended Display Identification Data
GbE	Gigabit Ethernet
Gbps	Gigabits per second
GUI	Graphical User Interface
HDCP	High-bandwidth Digital Content Protection
HDMI	High-Definition Multimedia Interface
HDR	High Dynamic Range
IP	Internet Protocol
kHz	Kilohertz
LAN	Local Area Network
LED	Light-Emitting Diode
LPCM	Linear Pulse-Code Modulation
MAC	Media Access Control
MHz	Megahertz
SNR	Signal-to-Noise Ratio
TCP	Transmission Control Protocol

ACRONYM	COMPLETE TERM
THD+N	Total Harmonic Distortion plus Noise
TMDS	Transition-Minimized Differential Signaling
4K UHD	4K Ultra-High-Definition (10.2Gbps max)
4K UHD⁺	4K Ultra-High-Definition (18Gbps max)
USB	Universal Serial Bus
VGA	Video Graphics Array
WUXGA (RB)	Widescreen Ultra Extended Graphics Array (Reduced Blanking)
XGA	Extended Graphics Array
Ω	Ohm



CYPRESS TECHNOLOGY CO., LTD.
www.cypress.com.tw
