

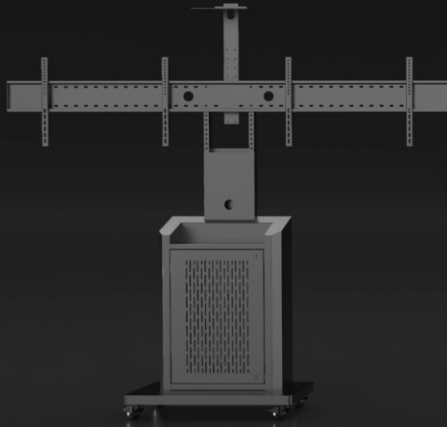

## DESCRIPTION

**nT07DD06B Slim 12U Cabinet dual display cart** is suitable for 42"-60" displays up to 70 Kgs. , compatible vesa up to 600 x 400 mm . It is a multipurpose AV cart with 19" - 12 u elegant slim storage cabinet for storage of A V equipment, devices and is reliable and strong. . With cable management, power strip, camera mount and storage cabinet at the base - the cart gives full flexibility for multiple applications and ease of use . The front cabinet door is lockable vented door for ventilation to reduce the heat generated by equipments . Heavy duty caster wheels enables smooth and easy movement . Suitable for Conference rooms , Huddle rooms, Training rooms , Educational , Hospital , Reception and digital signage applications .



## Specification

Material	:	Powder coated ms steel,Compatible
Display size	:	42"-60"
Weight	:	Max 70kgs
Vesa	:	200x200,200x400,400x400,600x400
Cabinet size	:	12 u - 600X881X276
PDU	:	6 Amps 6 Universal sockets
Caster wheels	:	M10
Color	:	Black
Shelf	:	1 camera shelf + 1 shelf in the cabinet
Lock and key	:	Front cabinet door
Height	:	2021
Door	:	Vented door with lock

## Cabin With Air Flow Vents

For Storing Device and other things

Keylocking Feature



Power Strip

Camera Mount

Extra space with  
Cable Routing

Webpage



Youtube



# SLIM CABINET DUAL CART

nT7DD06B

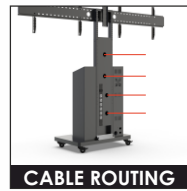
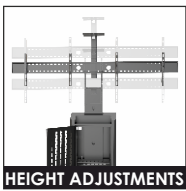
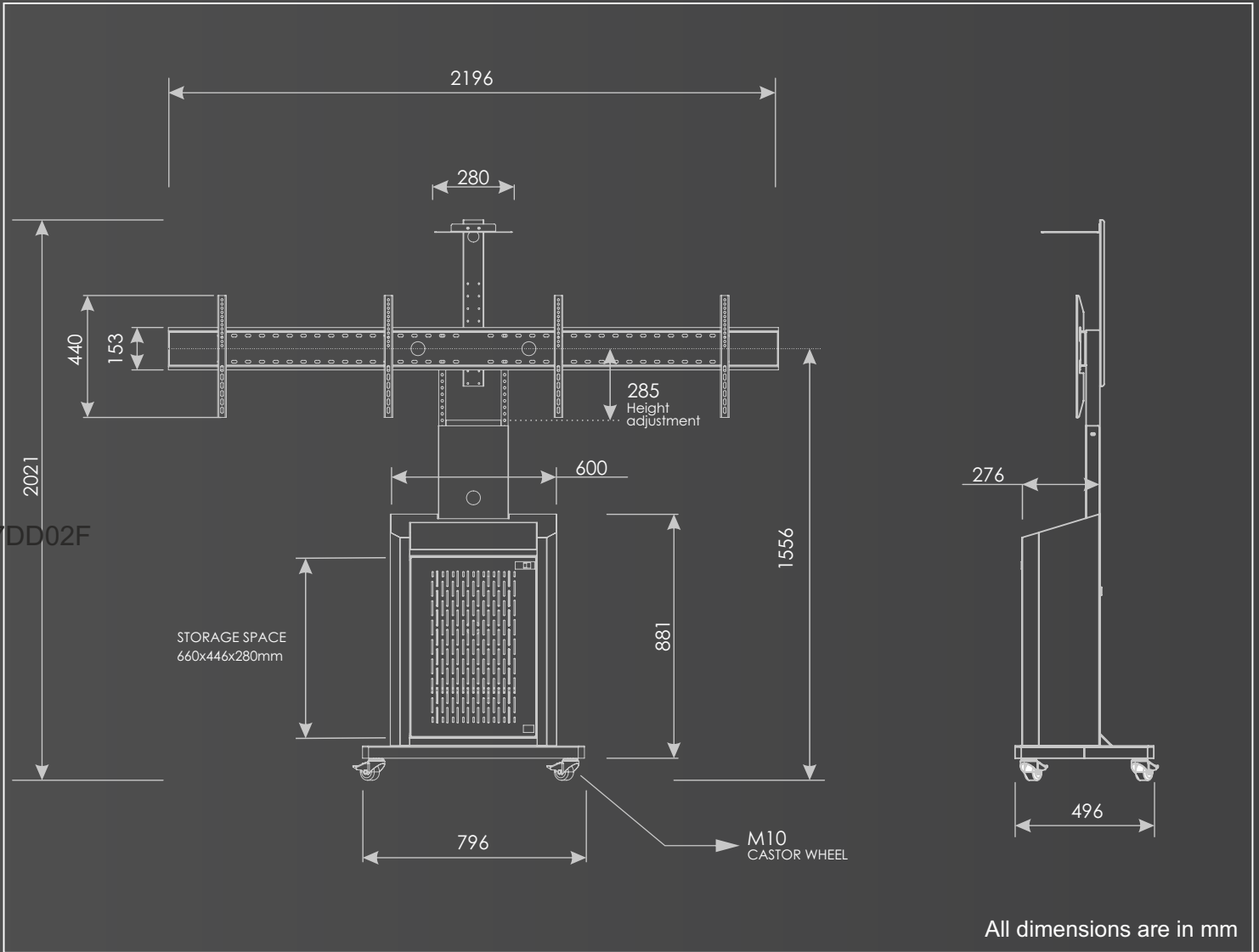

[www.ntindia.net](http://www.ntindia.net)