

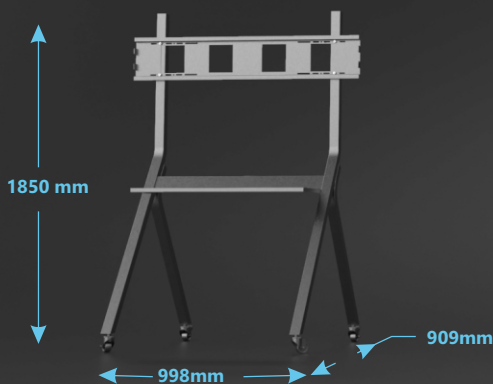

## DESCRIPTION

**nT7DD02F AXE series AV cart**, suitable for display panel up to 100 Kgs - with max vesa 1000 x 600 mm - suitable for 47 - 86 " displays and interactive panels . With 1 shelves .The cart is simple to assemble and best suitable for interactive panels . Available in Black and white colour . With sleek and small packing it is easy to carry and transport the cart, Suitable for Conference rooms , Huddel rooms , Training rooms , Educational , Hospital , Reception and digital signage applications .

**nT7DD02F AXE series AV cart** is madeup of powder coated cr steel . suitable for display panel up to 100 Kgs - Vesa Suported - 400x400 , 600x400 ,800x400 , 800x600 ,1000x400 , 1000 x 600 mm - suitable for 47 - 86 " displays and interactive panels . 1 Large shelf available . Available in Black and white colour .



## Specification

Material	:	Powder coated ms steel
Material thickness	:	2 mm
Weight capacity	:	100kgs
Height	:	1850mm
Vesa	:	400x400mm,600x400mm,800x400mm, 800x600mm,1000x400mm
Shelf	:	1(541 x 282mm)
Caster wheels	:	M10
Base size	:	908mmx909mm
Color	:	Black/White

## Heavy Duty Design



## With Storage Space



Webpage



Youtube



# FLOOR MOUNT TROLLEY - AXE

## nT7DD02F

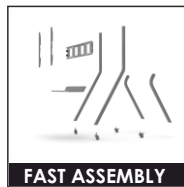
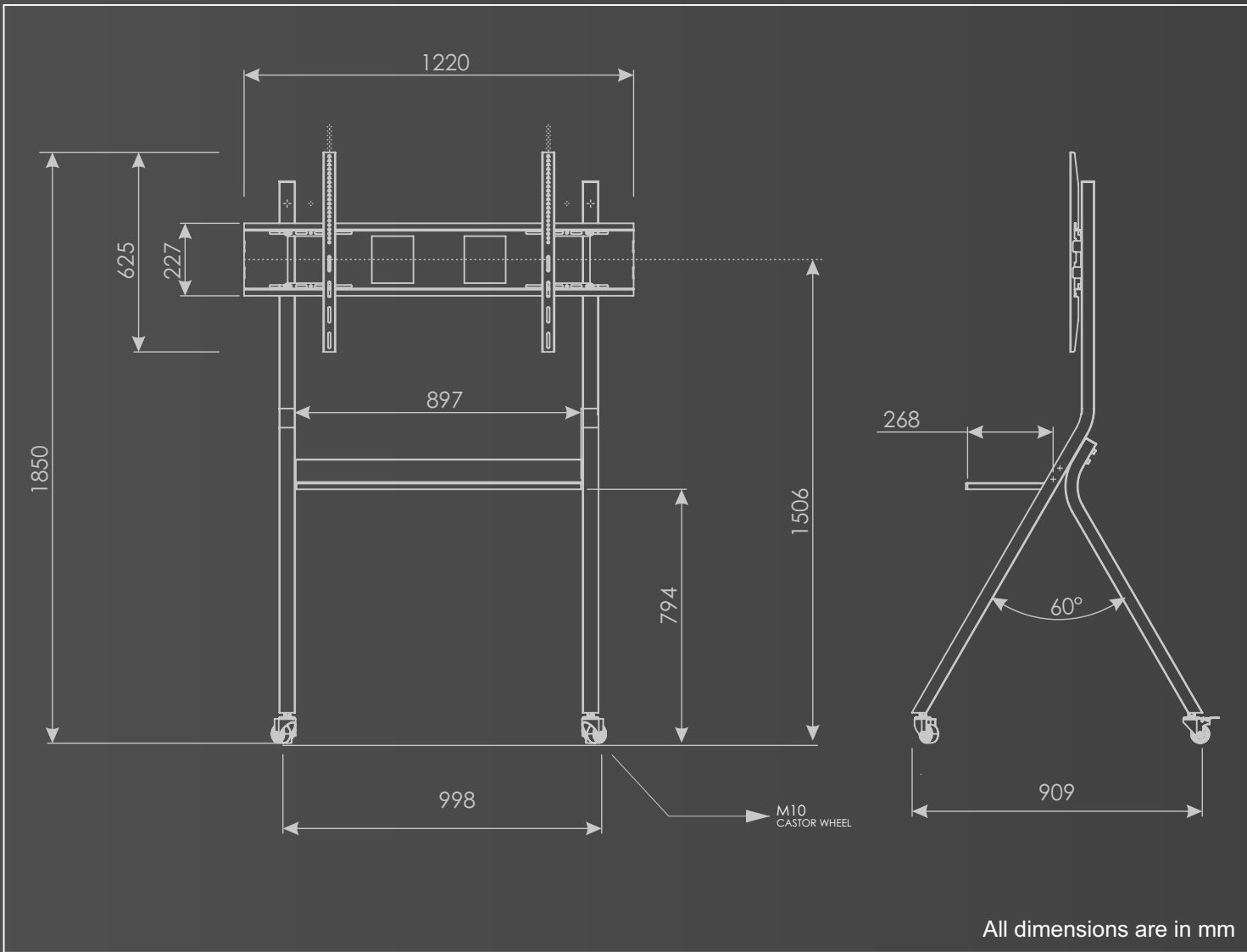

[www.ntindia.net](http://www.ntindia.net)