

WHITE

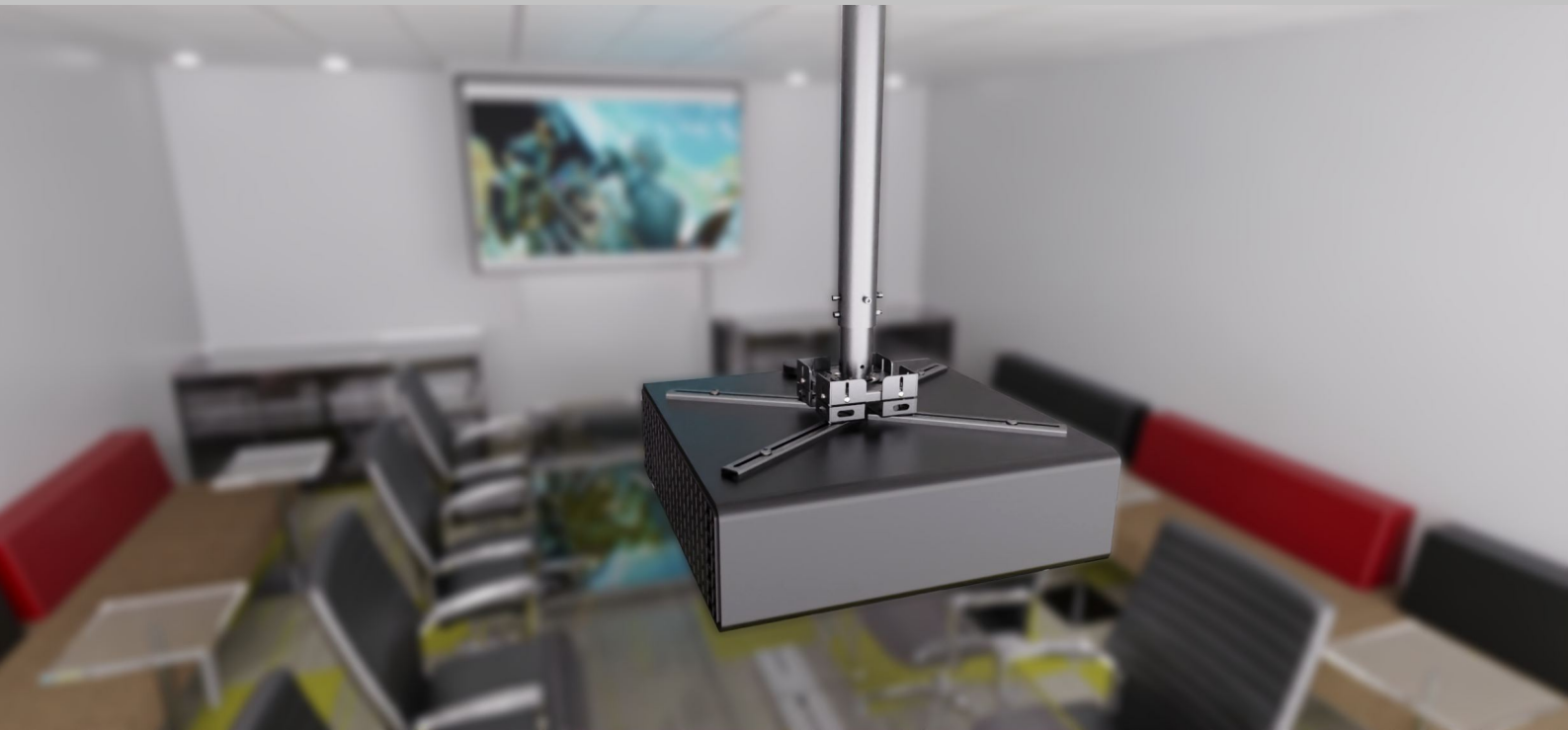

WHITE



## DESCRIPTION

The nT7CB06 is a ultra heavy projector ceiling mount best suited for heavy and large projectors . Easy installation with simple 360 degree rotation, micro adjustments - pan and tilt using the alen keys . Adjustable height , large mounting pitch ,Cable management through the telescopic pole.Weight capacity up to 50 kgs . Available in elegant Matt Black and Matt white colour with options of various drop down heights.

The nT7CB06 ultra heavy projector ceiling mount is made up of powder coated ms steel material . Supports 360 degree rotation , Pan and tilt micro adjustments - using the alen keys . Adjustable height with telescopic inner and outer tubes, Suitable for large mounting pitch up to 500 mm , Cable management through the telescopic pole.

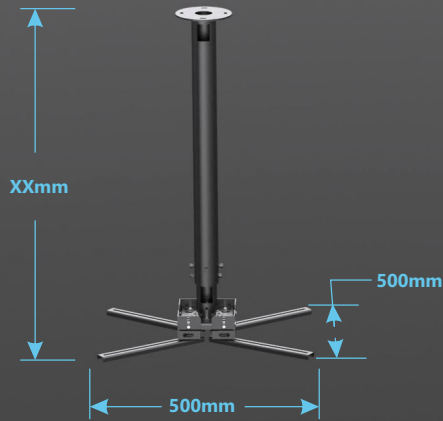

Available sizes :

- nT7CB06A - 1.5-2ft
- nT7CB06B - 2-3 ft
- nT7CB06C - 3-6 ft
- nT7CB06D - 6-10 ft
- Customized lengths

## Specification

Material	:	MS steel
Height adjustment	:	Sliding in inner and outer tube
Pan and tilt	:	Using alan key
Rotation	:	360 Degree - using telescopic poll
Mounting pitch	:	500 mm
Weight capacity	:	Up to 50 kgs
Height variants	:	1.5-2 ft, 2-3 ft, 2.5-4 ft, 3-6 ft
Color	:	Black/White

## Rigid Construction With Cable Routing

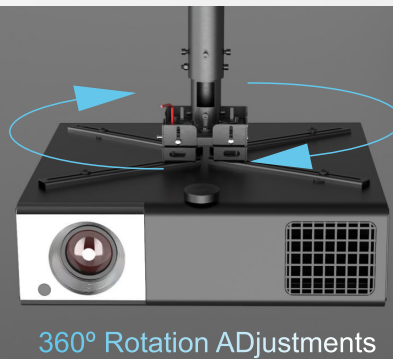
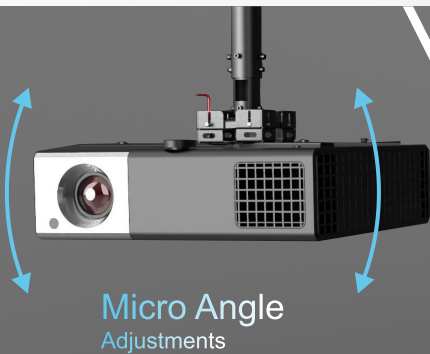
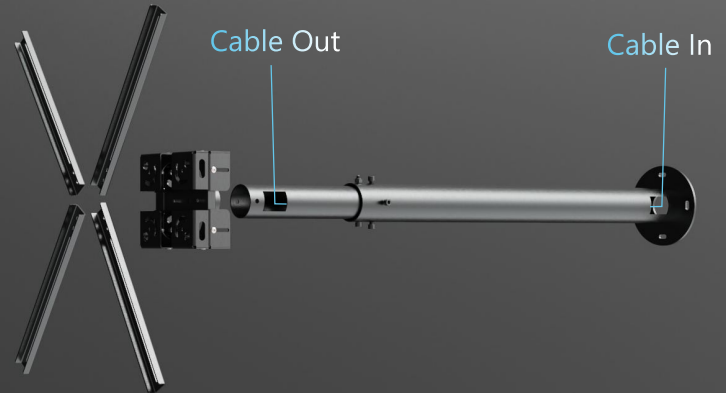

Webpage



Youtube



# ULTRA HEAVY DUTY PROJECTOR MOUNTS

nT07CB06

