



DESCRIPTION

nT04BX02 is a **UHD / 3G SDI BNC connector** specially designed for high resolution video signals. Supports up to 8K signals with low signal loss. It is available in different variants which is suitable for different cables like Mini Coax , Mini 59 ,59, 6, 6 dual shield ,11series Etc. and different brands such as nT, Belden, Cannare, Argosy, Kramer, Commscope, Draka Etc. This comes with high quality strain relief boot which gives extra support to the cable as well as the connector joint and prevents damage.

MODEL NO	HOUSING ID	PIN ID AND CRIMPING	FERRULE ID AND CRIMPING DIM	COMP CABLE
nT04BX02A	HOUSING ID - 2.70mm	PIN ID/CRIMP - 0.60/1.72mm	4,4-3.00/4.52-3,82mm	MINI COAX
nT04BX02B	HOUSING ID - 2.70mm	PIN ID/CRIMP - 0.60/1.72mm	4,4-3.00/4.52-3,82mm	MINI 59
nT04BX02C	HOUSING ID - 2.70mm	PIN ID/CRIMP - 0.60/1.72mm	4,4-3.00/4.52-3,82mm	59
nT04BX02D	HOUSING ID - 5.0mm	PIN ID/CRIMP - 1.20/1.72mm	7.5/7.35	6
nT04BX02E	HOUSING ID - 2.70mm	PIN ID/CRIMP - 0.60/1.72mm	4,4-3.00/4.52-3.81mm	6 DUAL SHIELD
nT04BX02F				11

3G SDI BNC MALE CONNECTOR

nT04BX02

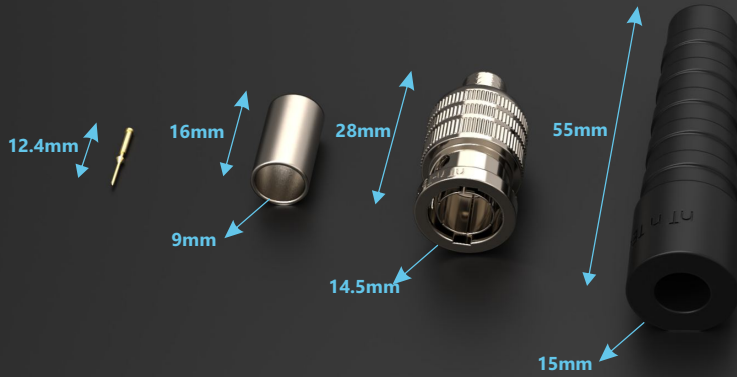

Description	Material	Finish
Shell	Brass	Nickel plated
Body	Brass	Nickel plated
Insulator	Teflon	Natural
Gasket	Rubber	Red
Spring	65mn	Natural
Washer	Iron	Nickel plated
Contact pin	Brass	Gold plated
Ferrule	Brass	Nickel plated

High Resolution Video Signals Upto 8K
with no Signal Loss



Crimping Details

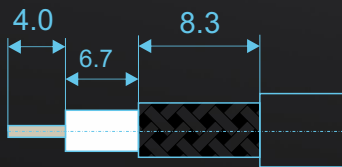

Webpage



Youtube



3G SDI BNC MALE CONNECTOR

nT04BX02

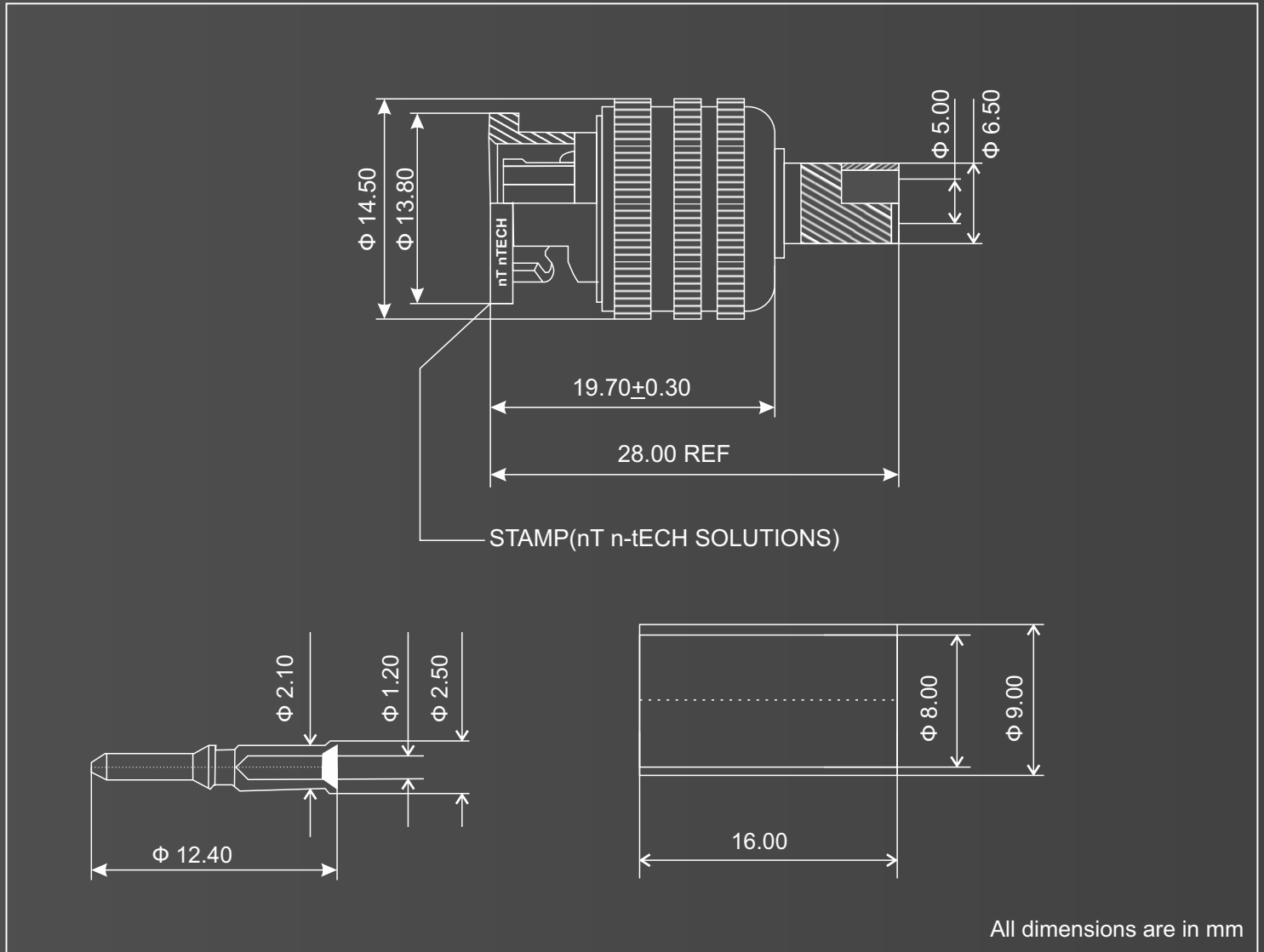

www.ntindia.net